

Sliding Door HD Bottom Rolling

Designed to meet the everyday rigors of the New Zealand built environment, the Heavy Duty range of sliding hardware moves very large doors effortlessly year in and year out.



Design Features

Stainless steel tyres coupled with a stainless track allow doors to be rolled with minimal effort, while being extremely smooth and whisper quiet.

Materials

Our heavy duty bottom roller is made almost entirely from stainless steel. Chosen for its excellent strength properties, as well as being extremely corrosion resistant. Our products are built with durability in mind, and will stand the test of time.

Testing

Thorough design and manufacturing controls, mean nothing without proof it will perform in the real world.

The Heavy Duty range has been subjected to extensive cycle and load testing, that simulate real world conditions, ensuring a long low service life.

Specifications

Specifications	Detail
Max Panel Weight	600kg
Max Panel Height	4m
Roller Width	25mm
Height Adjustable	+/- 5mm

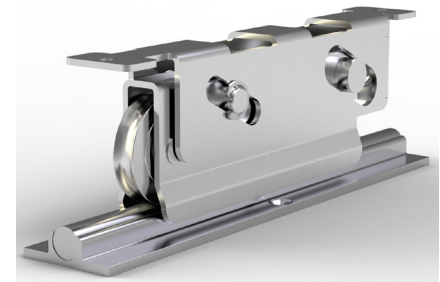

Components

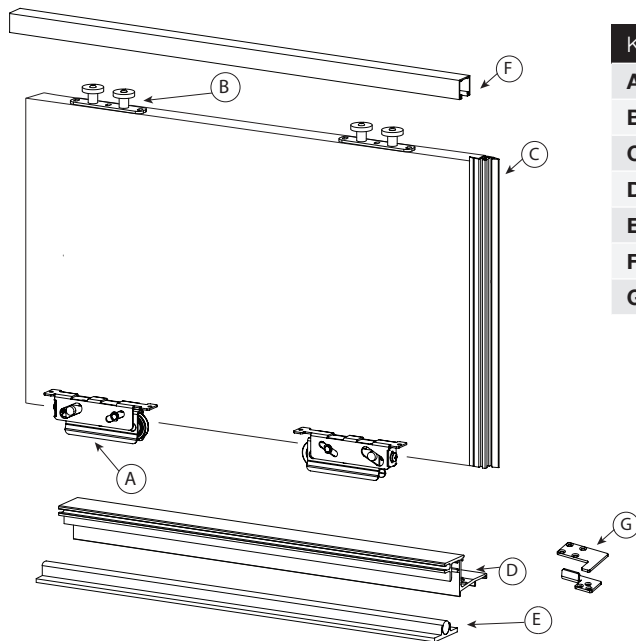

Key	
A	Bottom Roller
B	Top Guide
C	Interlocker
D	Threshold
E	Bottom Track
F	Top Track
G	Negative Load Hook

NZS 4211 Compliant System

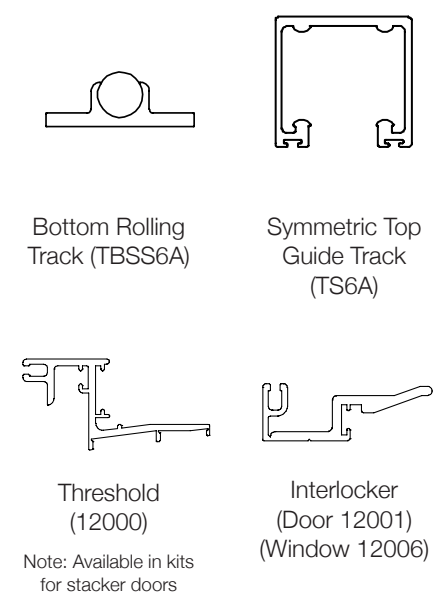

Accessories

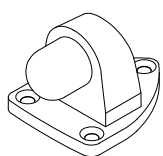

Door Stop 316 S/S (SDS26)

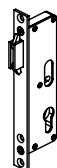

Sliding Lock (LCS40)

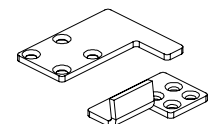

Negative Load Hooks S/S (12060LH or RH)

End View

Side View

